

Helical Hydraulic Rotary Actuators

L20 Series Service & Repair Manual



ENGINEERING YOUR SUCCESS.

Table of Contents

Introduction

Table of Contents	2
Product Introduction	3
General Safety Guidelines	3
Product Identification	4
Operation Technology	5

Tools

Tools Required	6
----------------------	---

Drawings

Spare Parts	7
Assembly Drawing, L20-4.5	8
Exploded View, L20-4.5	9
Assembly Drawing, L20-8.2, 15	10
Exploded View, L20-8.2, 15	11
Assembly Drawing, L20-25, 39	12
Exploded View, L20-25, 39	13
Parts List	14

Disassembly

Before Disassembly	20
End Cap Removal	20
Disassembly	25
Inspection	28

Assembly

Assembly	29
End Cap Installation	33

Post Assembly

Grease Thrust Washers	36
Testing the Actuator	37
Installation and Bleeding	38
Troubleshooting Guide	39
Offer of Sale	40

Product Introduction

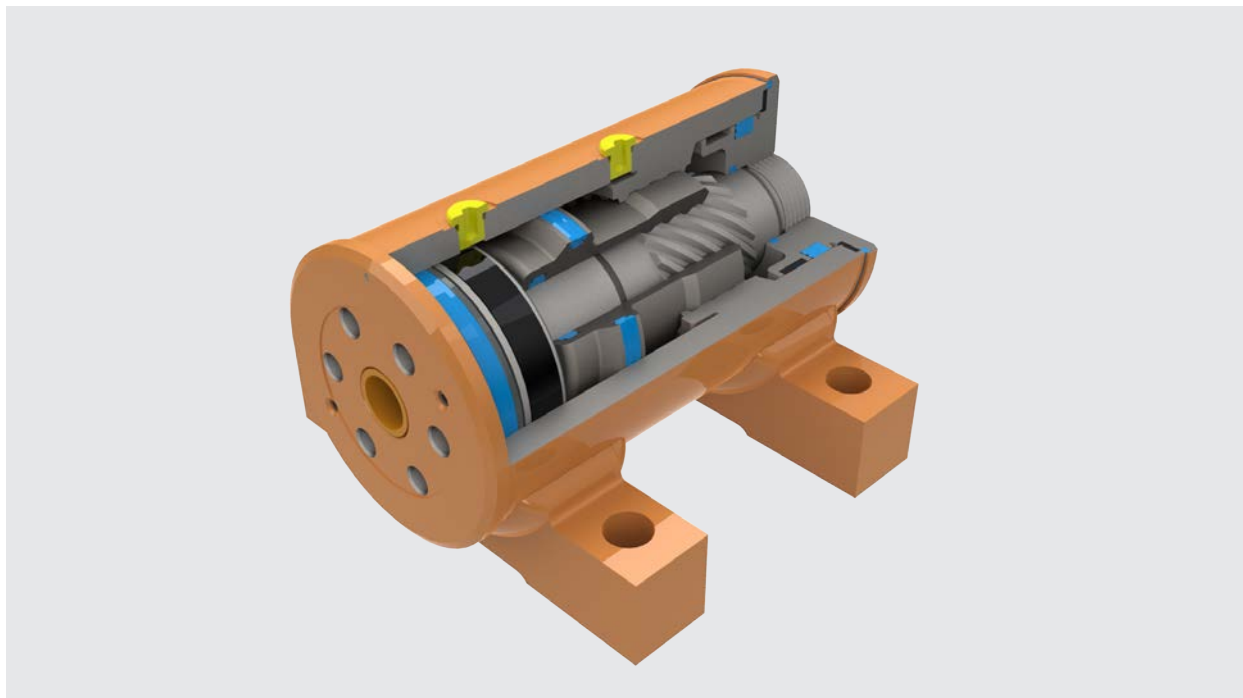

For over 50 years, Parker-Helac has been recognized for innovation in design of hydraulic rotary actuators and construction equipment attachments. Helac products are renowned for their tremendous torque output, compact configurations, exceptional load bearing capabilities, and rugged, reliable performance. Over 1,000 mobile, industrial, construction and mining machinery manufacturers around the world depend on Helac actuators to perform such functions as

rotation, positioning, manipulation, vehicle steering and indexing. Helac's L20 Series rotary actuators are used widely to rotate work platforms on self-propelled aerial lifts where they have become the industry standard.

The L20 Series is available in different sizes and various mounting configurations (for more details see page 4).

General Safety Guidelines

	⚠ WARNING
	Avoid personal injury and machinery damage: Read the Service and Repair Manual for proper installation, maintenance and repair procedures.

⚠ CAUTION
To avoid injury or damage to product: Secure product to slotted table or vise.

	⚠ CAUTION
	Spraying fluids. Contents under pressure. Wear approved eye protection. Use caution when removing port plugs and fittings.

NOTICE
To avoid contamination to machined parts: Make sure work area is clean.

Many L20 actuator applications have several pinch points with the potential for severe injuries. Use extreme caution and remain clear of all rotating components when bleeding the hydraulic system and whenever the machine is in operation.

After rebuilding or repairing an actuator, it is necessary to bleed all air from the actuator as well as the hydraulic system of the machine. See page 38 for bleeding instructions.

Exercise extreme caution while bleeding the actuator -- keep hands, fingers, and other limbs a safe distance from all rotating components.

Product Identification

Each Helac actuator is individually serial numbered. The serial number is a five or six digit number and must be provided before parts and/ or service issues can be addressed.

The serial number can be found on the Identification (ID) Tag that is affixed to all actuators. The tag is a thin, silver colored, plastic material with a self-adhesive backing. Information is imprinted in black. The tag is located either on the side plate or on the housing tube of the actuator. In some cases, the ID tag may be painted over by the OEM (Original Equipment

Manufacturer). Typical sample tag locations are seen below. Note that the model number may begin with either "HP" or "L20".

Additionally, the serial number of the actuator is stamped onto the side plate or the housing tube. It may be necessary to remove paint to expose the serial number.

If the ID tag is not attached to the actuator and/ or the stamped serial number cannot be located, the basic actuator model can be identified by measuring the outer diameter of the drilled and tapped shaft flange.

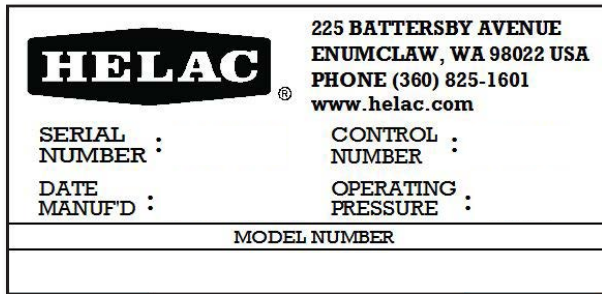

Model	Flange Diameter
L20-4.5	4.10" (104.14 mm)
L20-8.2	4.60" (116.84 mm)
L20-15	5.60" (142.24 mm)
L20-25	6.70" (170.18 mm)
L20-30	7.20" (182.88 mm)
L20-39	7.70" (195.58 mm)

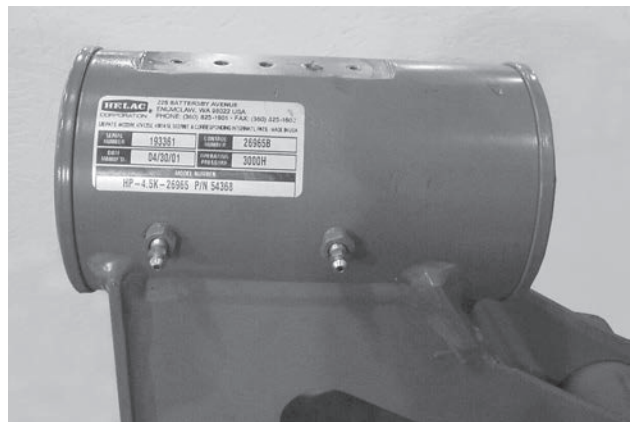

Operation Technology

The L20 Series rotary actuator is a simple mechanism that uses Helac's sliding spline technology which converts axial piston motion into powerful shaft rotation. As seen in the illustration below left, each actuator is composed of a housing with an integral ring gear (1) and only two moving parts: the central shaft (2), and the annular piston sleeve (3). Note the L20 actuator shaft features an integral mounting flange and bearing which are not shown in the illustration.

Helical spline teeth machined on the shaft engage matching splines on the inside diameter of the piston. The outside diameter of the piston carries a second set of splines, of opposite hand, which engage the matching splines of the housing's ring gear.

As hydraulic pressure is applied, the piston is displaced axially within the housing - similar to the operation of a hydraulic cylinder - while, simultaneously, the splines cause the shaft to rotate. When the control valve is closed, oil is trapped inside the housing, preventing piston movement and locking the shaft firmly in position.

The shaft is supported radially by the large upper radial bearing and the lower radial bearing (see drawings on pages 8-11). Axially, the shaft is separated from the housing by the upper and lower thrust washers. The end cap is adjusted for axial clearance and locked in position by set screws or pins.

The L20 Series is available in several different sizes. All L20 Series actuators have the same internal design and basic components, though configurations of parts may be slightly different depending on model.

Many L20 actuators are equipped with factory installed counterbalance valves, which perform four major functions.

- Protects the actuator in the event of overload
- Enables the actuator to hold position without drifting when external loads are applied
- Reduces hydraulic backlash by pressuring the hydraulic fluid
- Provides a constant controlled rate of rotation in over-center load conditions

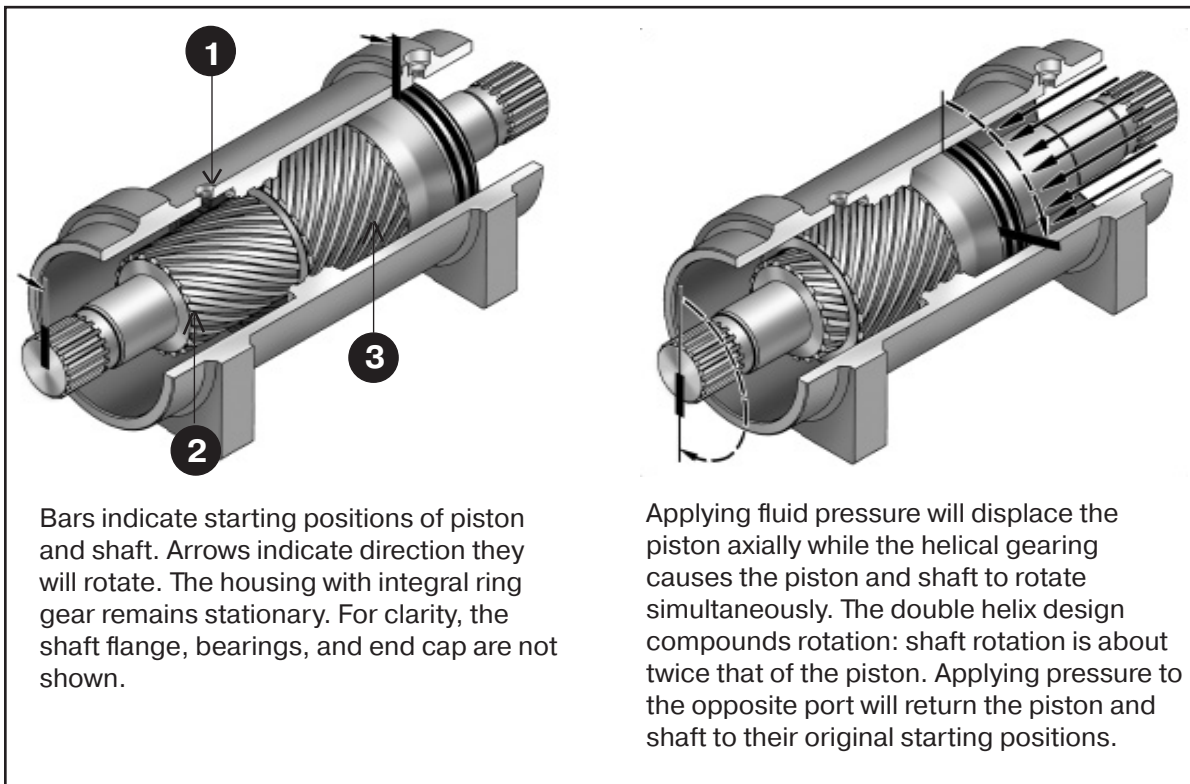

Tools Required

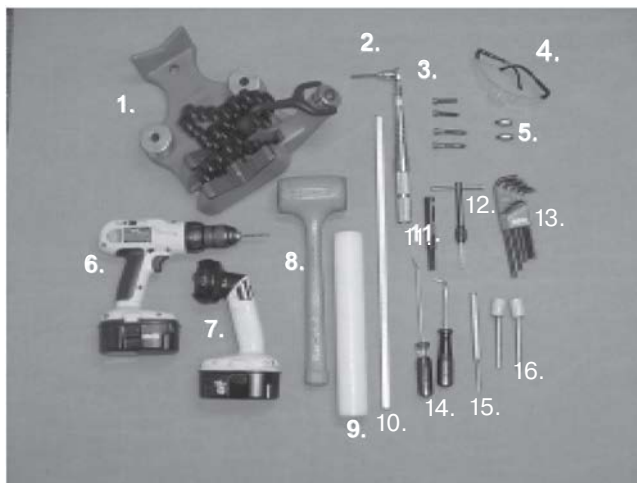

Several basic tools are required for the disassembly and reassembly of the actuator. The tools and their intended functions are outlined below:

- 1. PIPE VISE**
- 2. TORQUE WRENCH**
Removal and replacement of port plugs and set screws.
- 3. ASSORTED SCREWS**
- 4. SAFETY GLASSES**
- 5. END CAP REMOVAL TOOLS** (provided with Helac seal kit).
- 6. DRILL**
- 7. FLASHLIGHT**
Helps in locating and examining timing marks, component failure and overall condition.
- 8. RUBBER MALLETT**
Removal and installation of shaft and piston sleeve assembly.
- 9. PLASTIC MANDREL**
- 10. PRY BAR**
Removal of end cap and manual rotation of shaft.
- 11. FELT MARKER**
Highlights timing marks and outlines troubled areas. Permanent ink is recommended.
- 12. T-HANDLE SCREW EXTRACTOR**
- 13. HEX WRENCH SET**
Removal and replacement of port plugs and set screws (106,113).

14. SEAL TOOLS

Removal and installation of seals and wear guides. Directions on making a seal tool are provided at bottom.

15. PUNCH

16. DOWEL PINS

Removal and installation of end cap.

MAKING A SEAL TOOL

The seal tool is merely a customized standard flat head screwdriver.

1. Heat the flat end with a torch until it glows.
2. Secure the heated end of the screwdriver in a vise and bend the heated end to a slight radius.
3. Round off all sharp edges of the heated end to a polished finish. The tool may be modified slightly to your own personal preference.

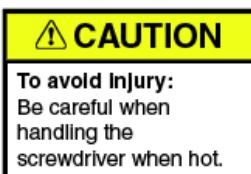

Spare Parts

Spare parts must be ordered through the vehicle/machine OEM. Seals and bearings are available as complete kits only. In order to obtain the correct parts, it is essential to provide the serial number of the actuator to be repaired, see

Product Identification section on page 4. To identify spare parts required, refer to the Assembly Drawings on page 8-13 and Parts List on page 14.

Spare Parts

Technical support is available from Parker Hannifin, Monday through Friday 7 am to 3:30 pm Pacific Standard Time by calling 800-327-2589. If possible, please have the serial number of the actuator available. (The serial number is stamped into the housing of the actuator-see page 4).

Assembly Drawing - L20-4.5

Typical L20 Series Actuator
Clevises May Be Different

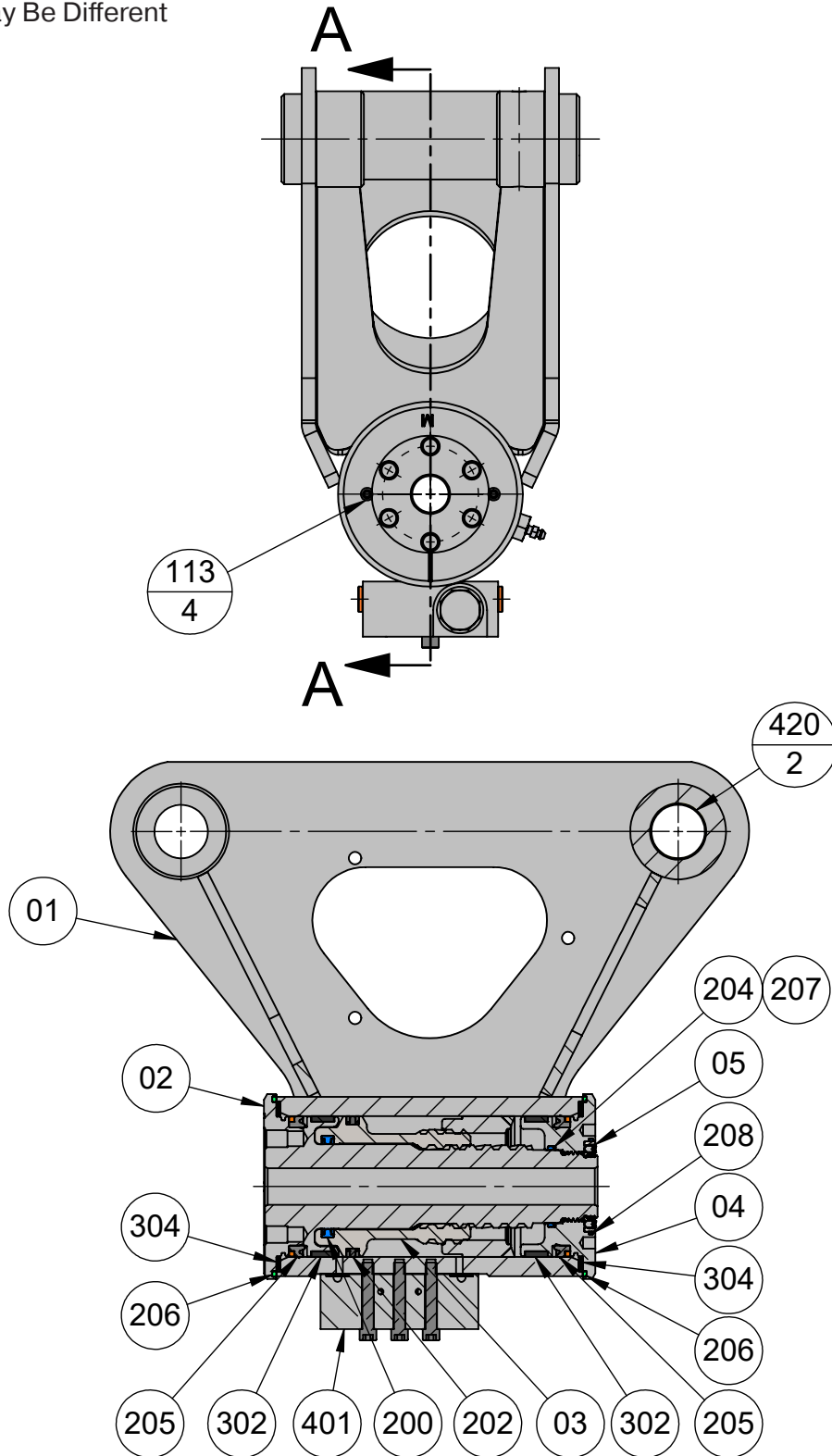

Exploded View - L20-4.5

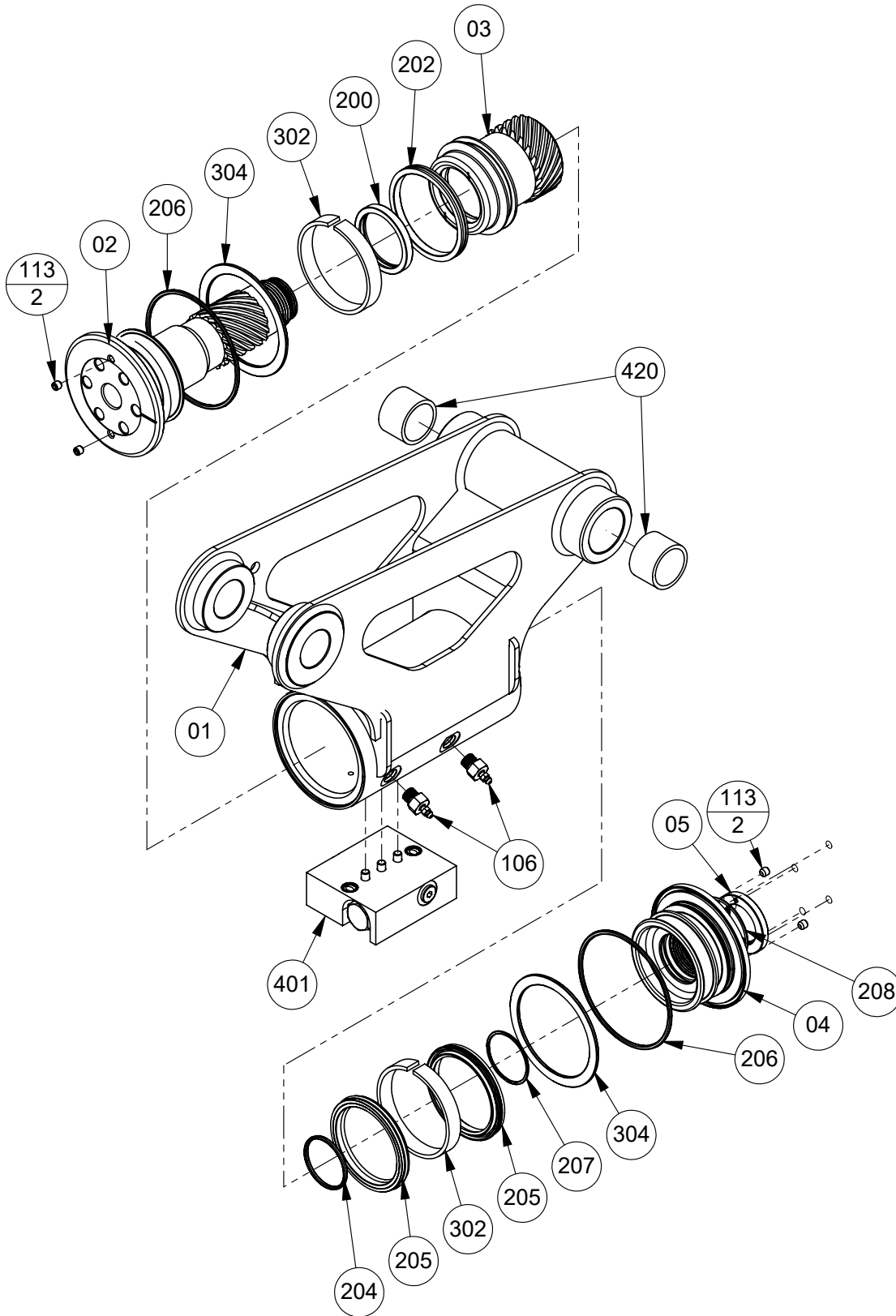

Assembly Drawing - L20-8.2 and 15

Typical L20 Series Actuator
Clevises May Be Different

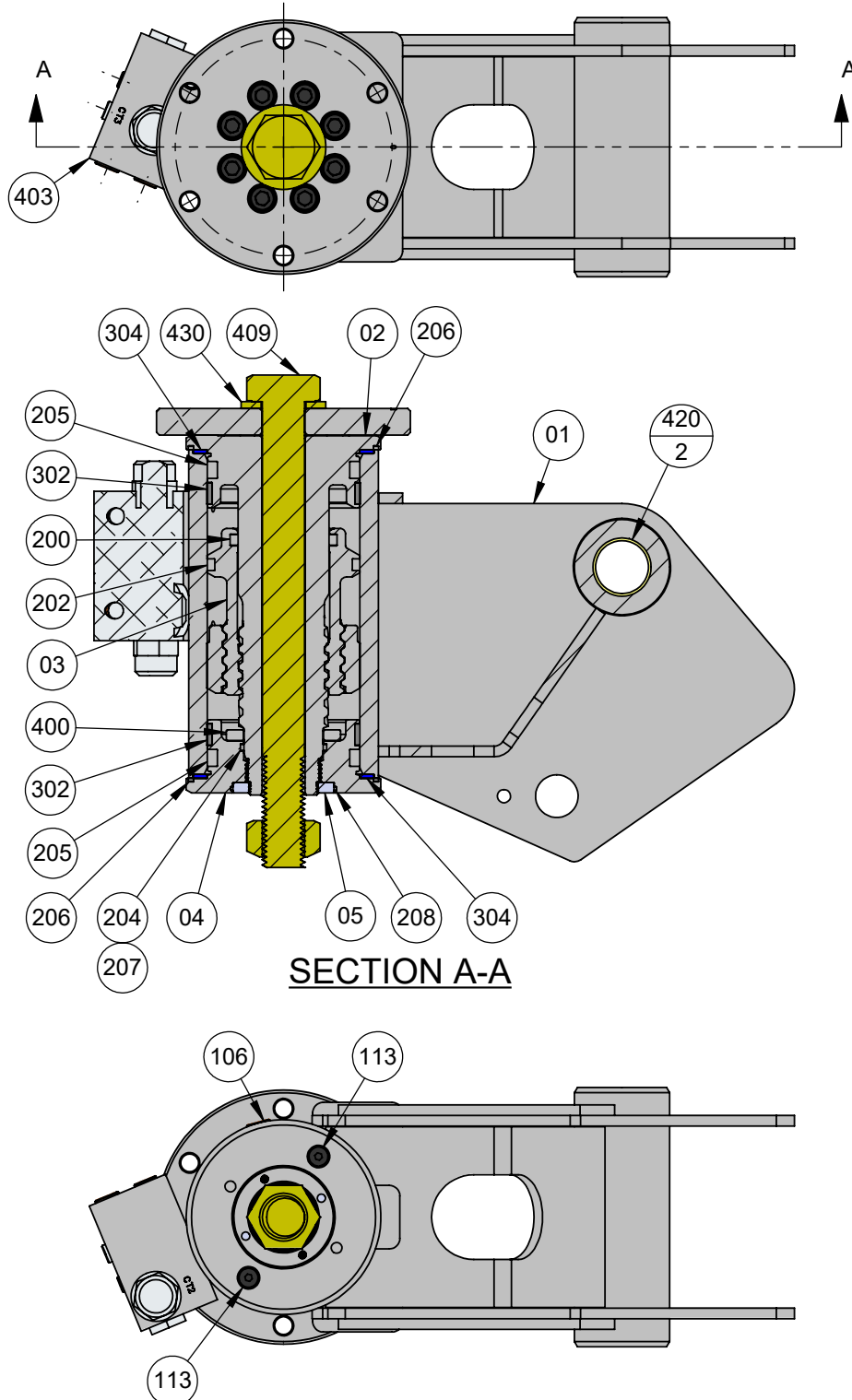

Exploded View - L20-8.2 and 15

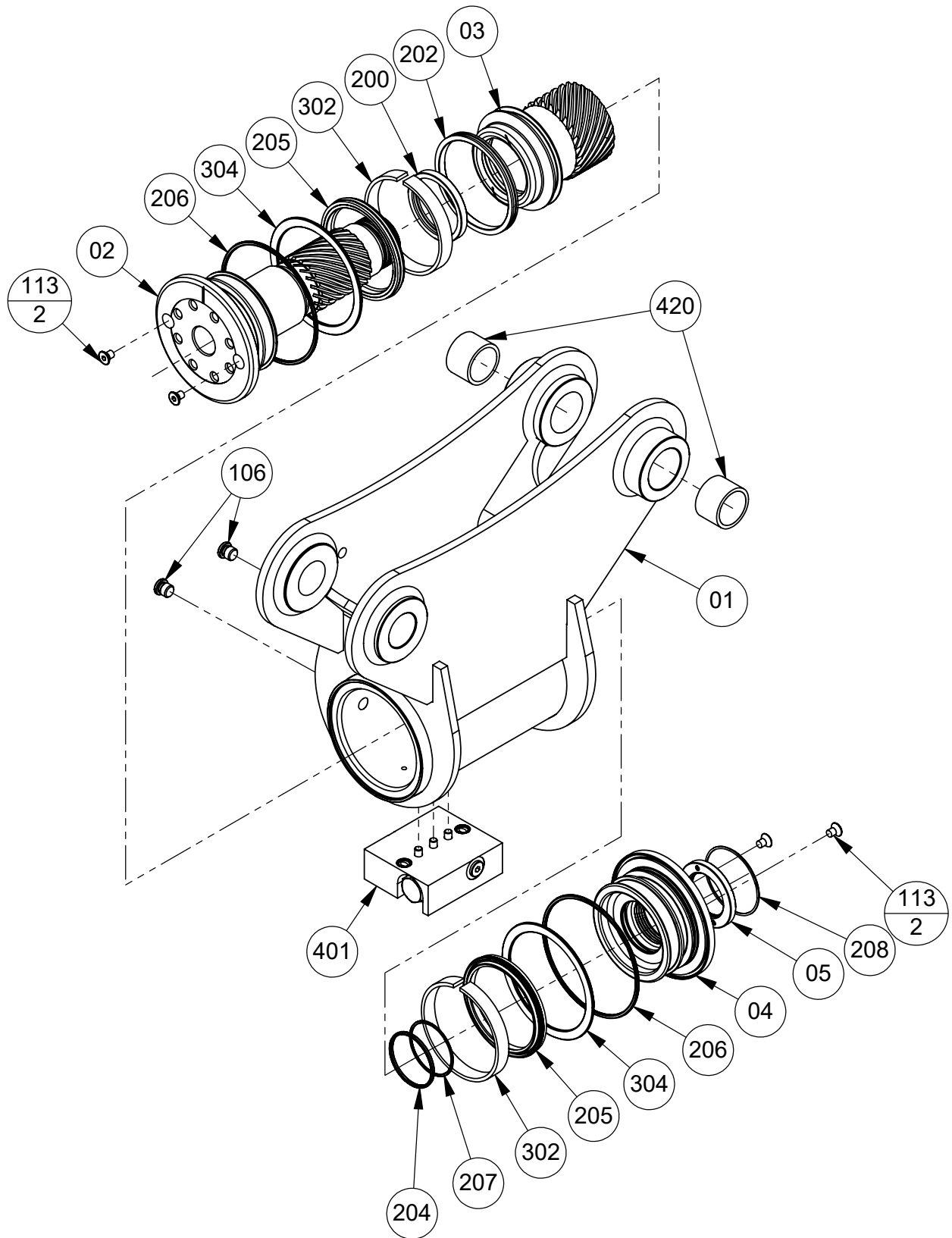

Assembly Drawing - L20-25 and 39

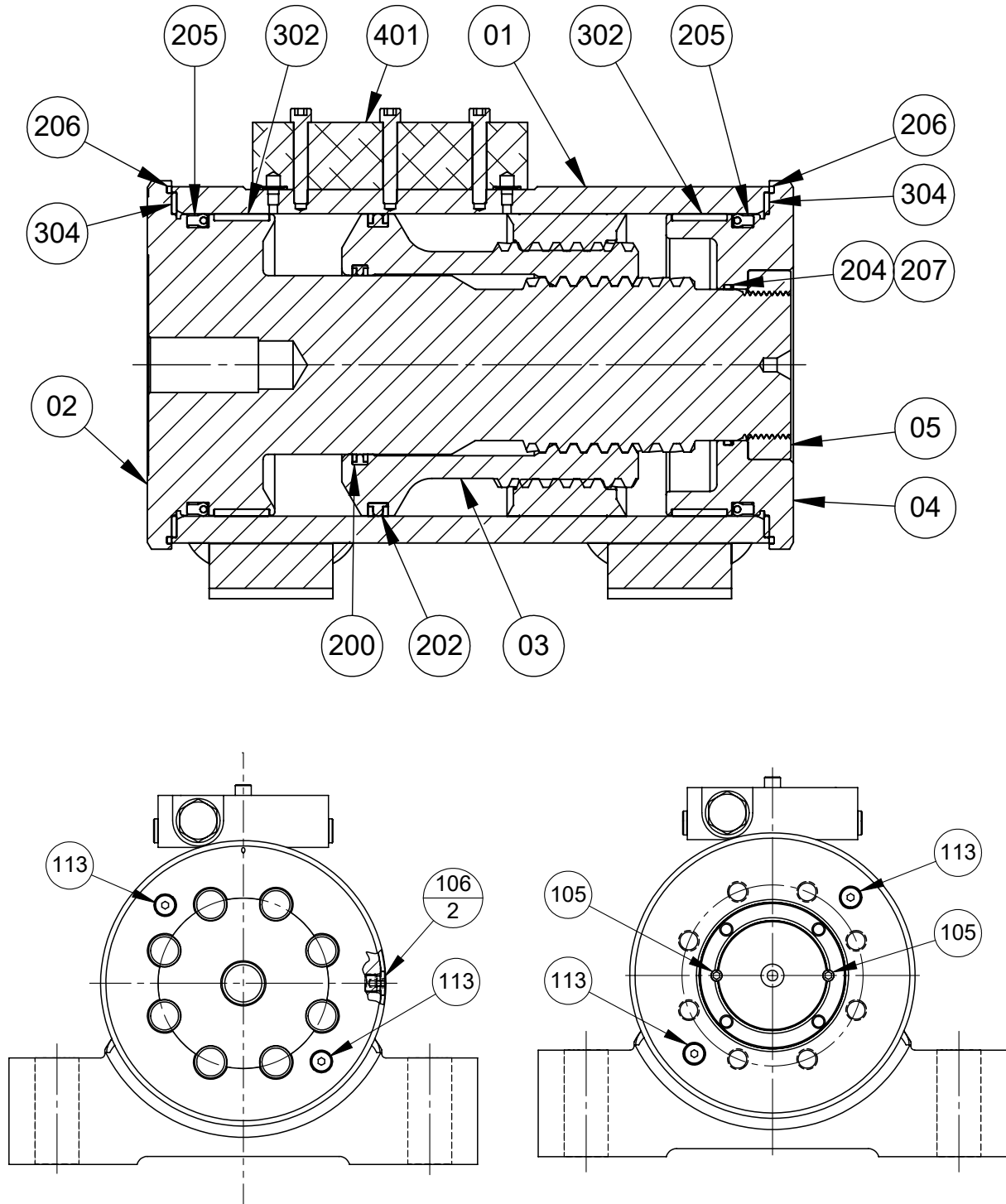

Exploded View - L20-25 and 39

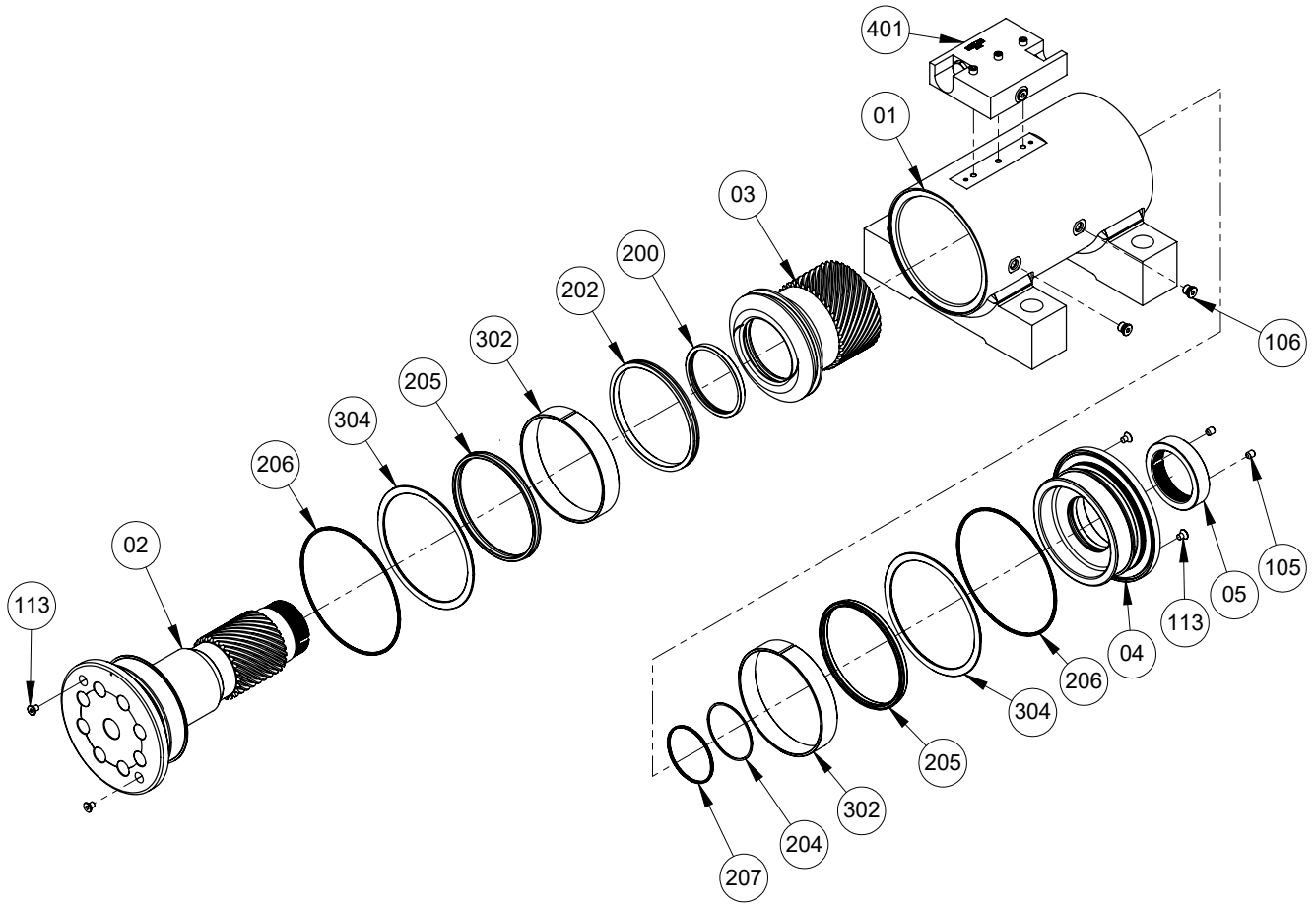

Parts List - L20-4.5

Parts listed are standard components per the catalog. Parker-Helac has and does make special designs for OEM's that may differ. Model codes beginning with L20-4.5-S, L20-4.5-ES or L20-4.5-MS could use different parts.

"E" Shaft tapped for SAE bolts. SAE oil ports in housing and thru holes in foot for SAE bolts.

"M" Shaft tapped for metric bolts. SAE oil ports in housing and thru holes in foot for metric bolts.

Parts

Part Number	Item #	Description	Qty
OEM	01	Housing - Clevis Mount (contact OEM of equipment installed on)	1
27068-2	01	Housing - "E" Foot Mount (no valve flat)	1
27068	01	Housing - "E" Foot Mount (with valve flat)	1
33967-2	01	Housing - "M" Foot Mount (no valve flat)	1
33967	01	Housing - "M" Foot Mount (with valve flat)	1
S37272	02	Shaft "E"	1
	04	End Cap	1
	05	Lock Ring Assembly	1
S37273	02	Shaft "M"	1
	04	End Cap	1
	05	Lock Ring Assembly	1
26811	03	Piston Sleeve	1
941009	103	Sealing screw (SeelSkrew R10-24X1/4-4601) pan head (if used)	2
S26259-2		Hardware Kit for Standard Foot Mount (includes item 105, 106, 109, 113)	
	105	Screw (Socket hex flat head; 1/4"-20 x .375, Grade 8)	2
	106	Port Plug (SAE-4)	4
	109*	Dowel pin .312" x .50" long (newer units use 1 pin only)	1
	113*	Set Screw (Socket head; 1/4"-20 x .25", Grade 8)	4
OEM	420 & 422	Pin Bushings (contact OEM of equipment installed on)	
931069	421	Bushing "E" (for .75" tie-rod bolt)	2
931068	421	Bushing "M" (for 20 mm tie-rod bolt)	2
52125		Bleeder valve assembly (SAE-4)	2
S26553	401	Standard Counterbalance Valve Kit: 2 x SAE-4 Ports (includes valve, mounting screws and o-rings) Top of valve stamped 26554	
		CB Valve	1
		Socket head cap screw; 1/4"-20 x 1.50" ASTM A574	3
		Port plug; SAE-4 Hollow hex, o-ring	2

*Items included in seal kit

Part Number	Item #	Description	Qty
34954	401	Standard Counterbalance Valve Kit: 2 x BSPP G1/4 Ports (includes valve, mounting screws and o-rings) Top of valve stamped 34955	
		CB Valve	1
		Socket head cap screw; 1/4"-20 x 1.50" ASTM A574	3
		Port plug; BSPP G1/4	2
S37061		Seal Kit Standard (Includes items below)	
	End cap removal tool	Special dowel pins and socket head screws: 1/4"-20 x 1.00", ASTM 574	2
	109	Dowel pin .312" x .50" long (older units use 2 pins)	2
	113	Set Screw (Socket head; 1/4"-20 x .25", Grade 8)	2
	200	T-Seal	1
	202	T-Seal	1
	204	O-ring	1
	205	Cup Seal	2
	206	O-ring	2
	207	Back-up ring	1
	208	Lock Ring O-ring	1
117	Lock Ring Removal Dowel Pins	2	
S28008		Bearing Kit (Includes item below)	
	302	Bearing	2
	304	Thrust washer	2

Parts in kits not sold individually

Note: Parker-Helac supplies many different counterbalance and motion control valves specific to an OEM application. If the valve you have is not one of the part numbers listed, contact the OEM of the equipment installed on to purchase the correct valve.

Seal kits can be ordered online at

<http://www.parker.com/helac>

Parts List - L20-8.2

Parts listed are standard components per the catalog. Parker-Helac has and does make special designs for OEM's that may differ. Model codes beginning with L20-8.2-S, L20-8.2-ES or L20-8.2-MS could use different parts.

"E" Shaft tapped for SAE bolts. SAE oil ports in housing and thru holes in foot for SAE bolts.

"M" Shaft tapped for metric bolts. SAE oil ports in housing and thru holes in foot for metric bolts.

Parts

Part Number	Item #	Description	Qty
OEM	01	Housing - Clevis Mount (contact OEM of equipment installed on)	1
27065-2	01	Housing - "E" Foot Mount (no valve flat)	1
27065	01	Housing - "E" Foot Mount (with valve flat)	1
33965-2	01	Housing - "M" Foot Mount (no valve flat)	1
33965	01	Housing - "M" Foot Mount (with valve flat)	1
S37274	02	Shaft "E"	1
	04	End Cap	1
	05	Lock Ring Assembly	1
S37275	02	Shaft "M"	1
	04	End Cap	1
	05	Lock Ring Assembly	1
26802	03	Piston Sleeve	1
941009	103	Sealing screw (SeelSkrew R10-24X1/4-4601) pan head (if used)	2
S26343-5		Hardware Kit for Standard Foot Mount (includes item 105, 106, 109, 113)	
	106	Port Plug (SAE-4)	4
	109*	Dowel pin .312" x .50" long (newer units use 1 pin only)	1
	113*	Screw (Socket hex flat head; 1/4"-20 x .375, Grade 8)	6
OEM	420 & 422	Pin Bushings (contact OEM of equipment installed on)	
931070	421	Bushing "E" (for 1" tie-rod bolt)	2
29161	421	Bushing "M" (for 24 mm tie-rod bolt)	2
52125		Bleeder valve assembly (SAE-4)	1
S26553	401	Standard Counterbalance Valve Kit: 2 x SAE-4 Ports (includes valve, mounting screws and o-rings) Top of valve stamped 26554	
		CB Valve	1
		Socket head cap screw; 1/4"-20 x 1.50" ASTM A574	3
		Port plug: SAE-4 Hollow hex, o-ring	2

*Items included in seal kit

Part Number	Item #	Description	Qty
34954	401	Standard Counterbalance Valve Kit: 2 x BSPP G1/4 Ports (includes valve, mounting screws and o-rings) Top of valve stamped 34955	
		CB Valve	1
		Socket head cap screw; 1/4"-20 x 1.50" ASTM A574	3
		Port plug: BSPP G1/4	2
S37062		Seal Kit Standard (Includes items below)	
	End cap removal tool	Special dowel pins and socket head screws: 1/4"-20 x 1.00", ASTM 574	2
	109	Dowel pin .312" x .50" long (older units use 2 pins)	2
	200	T-Seal	1
	202	T-Seal	1
	204	O-ring	1
	205	Cup Seal	2
	206	O-ring	2
	207	Back-up ring	1
	208	Lock Ring O-ring	1
	117	Lock Ring Removal Dowel Pins	2
S26807		Bearing Kit (Includes item below)	
	302	Bearing	2
	304	Thrust washer	2

Parts in kits not sold individually

Note: Parker-Helac supplies many different counterbalance and motion control valves specific to an OEM application. If the valve you have is not one of the part numbers listed, contact the OEM of the equipment installed on to purchase the correct valve.

Seal kits can be ordered online at

<http://www.parker.com/helac>

Parts List - L20-15

Parts listed are standard components per the catalog. Parker-Helac has and does make special designs for OEM's that may differ. Model codes beginning with L20-15-S, L20-15-ES or L20-15-MS could use different parts.

"E" Shaft tapped for SAE bolts. SAE oil ports in housing and thru holes in foot for SAE bolts.

"M" Shaft tapped for metric bolts. SAE oil ports in housing and thru holes in foot for metric bolts.

Parts

Part Number	Item #	Description	Qty
OEM	01	Housing - Clevis Mount (contact OEM of equipment installed on)	1
26613-2	01	Housing - "E" Foot Mount (no valve flat)	1
26613-1	01	Housing - "E" Foot Mount (with valve flat)	1
27969-2	01	Housing - "M" Foot Mount (no valve flat)	1
27969-1	01	Housing - "M" Foot Mount (with valve flat)	1
S37277	02	Shaft "E"	1
	04	End Cap	1
	05	Lock Ring Assembly	1
S37278	02	Shaft "M"	1
	04	End Cap	1
	05	Lock Ring Assembly	1
26595	03	Piston Sleeve	1
941009	103	Sealing screw (SeelSkrew R10-24X1/4-4601) pan head (if used)	2
S26896-4		Hardware Kit for Standard Foot Mount (includes item 105, 106, 109, 113)	
	106	Port Plug (SAE-4)	4
	109*	Dowel pin .312" x .50" long (newer units use 1 pin only)	1
	113*	Screw (Socket hex flat head; 1/4"-20 x .375, Grade 8)	6
OEM	420 & 422	Pin Bushings (contact OEM of equipment installed on)	
931070	421	Bushing "E" (for 1" tie-rod bolt)	2
29161	421	Bushing "M" (for 24 mm tie-rod bolt)	2
52125		Bleeder valve assembly (SAE-4)	1
S26553	401	Standard Counterbalance Valve Kit: 2 x SAE-4 Ports (includes valve, mounting screws and o-rings) Top of valve stamped 26554	
		CB Valve	1
		Socket head cap screw; 1/4"-20 x 1.50" ASTM A574	3
		Port plug: SAE-4 Hollow hex, o-ring	2
34954	401	Standard Counterbalance Valve Kit: 2 x BSPP G1/4 Ports (includes valve, mounting screws and o-rings) Top of valve stamped 34955	
		CB Valve	1
		Socket head cap screw; 1/4"-20 x 1.50" ASTM A574	3
		Port plug: BSPP G1/4	2

Part Number	Item #	Description	Qty
S37063		Seal Kit Standard (Includes items below)	
	End cap removal tool	Special dowel pins and socket head screws: 1/4"-20 x 1.00", ASTM 574	2
	109	Dowel pin .312" x .50" long (older units use 2 pins)	2
	109	Dowel pin .375 x .50 long (for HP-15 versions)	2
		L20-15 Standard Seal Kit	
	200	T-Seal	1
	202	T-Seal	1
	204	O-ring	1
	205	Cup Seal	2
	206	O-ring	2
	207	Back-up ring	1
	208	Lock ring O-ring	1
	117	Lock Ring Removal Dowel Pins	2
		HP-15 Standard Seal Kit (fore-runner of L20-15)	
	200	T-Seal	1
	202	T-Seal	1
	204	O-ring	1
	205	Cup Seal	2
	207	Back-up ring	1
	208	Lock Ring O-ring	1
117	Lock Ring Removal Dowel Pins	2	
S26895		Bearing Kit (Includes item below)	
	302	Bearing	2
	304	Thrust washer	2

Parts in kits not sold individually

*Items included in seal kit

Note: Parker-Helac supplies many different counterbalance and motion control valves specific to an OEM application. If the valve you have is not one of the part numbers listed, contact the OEM of the equipment installed on to purchase the correct valve.

Seal kits can be ordered online at

<http://www.parker.com/helac>

Parts List - L20-25

Parts listed are standard components per the catalog. Parker-Helac has and does make special designs for OEM's that may differ. Model codes beginning with L20-25-S, L20-25-ES or L20-25-MS could use different parts.

"E" Shaft and end cap tapped for SAE bolts. SAE oil ports in housing.

"M" Shaft and end cap tapped for metric bolts. SAE oil ports in housing.

Parts

Part Number	Item #	Description	Qty
OEM	01	Housing - Clevis Mount (contact OEM of equipment installed on)	1
27824-2	01	Housing - Foot Mount (no valve flat) SAE-4 ports	1
27824-1	01	Housing - Foot Mount (with valve flat) SAE-4 ports	1
31929	02	Shaft "E"	1
32001	02	Shaft "M"	1
27148	03	Piston Sleeve	1
27147	04	End Cap "E"	1
29852	04	End Cap "M"	1
27152	05	Lock Ring	1
941009	103	Sealing screw (SeelSkrew R10-24X1/4-4601) pan head (if used)	2
27504		Hardware Kit (Includes item 105, 106, 113)	
	105	Set screw (Socket head; 5/16"-18 x .375")	2
	106	Port Plug (SAE-4)	4
	113	Screw (Socket hex flat head; 1/4"-20 x .375, Grade 8)	4
OEM	420 & 422	Pin Bushings (contact OEM of equipment installed on)	
S27357	401	Standard Counterbalance Valve Kit: 2 x SAE-4 Ports (includes valve, mounting screws and o-rings) Top of valve stamped 27322	
		CB Valve	1
		Socket head cap screw; 1/4"-20 x 1.50" ASTM A574	3
		Port plug: SAE-4 Hollow hex, o-ring	2
S26553	401	Standard Counterbalance Valve Kit: 2 x SAE-4 Ports (includes valve, mounting screws and o-rings) Top of valve stamped 26554	
		CB Valve	1
		Socket head cap screw; 1/4"-20 x 1.50" ASTM A574	3
		Port plug: SAE-4 Hollow hex, o-ring	2

Note: Parker-Helac supplies many different counterbalance and motion control valves specific to an OEM application. If the valve you have is not one of the part numbers listed, contact the OEM of the equipment installed on to purchase the correct valve.

Part Number	Item #	Description	Qty
S27502		Seal Kit Standard (Includes items below)	
	200	T-Seal	1
	202	T-Seal	1
	204	O-ring	1
	205	Cup Seal	2
	206	O-ring	2
	207	Back-up ring	1
S27503		Bearing Kit (Includes item below)	
	302	Bearing	2
	304	Thrust Washer	2

Parts in kits not sold individually

Seal kits can be ordered online at

<http://www.parker.com/helac>

Parts List - L20-30

All L20-30 actuators are proprietary clevis mount housings designs. Parts listed are standard components.

"E" Shaft and end cap tapped for SAE bolts.

"M" Shaft and end cap tapped for metric bolts.

Parts

Part Number	Item #	Description	Qty
OEM	01	Housing - Clevis Mount (contact OEM of equipment installed on)	1
27925	02	Shaft "E"	1
29835	02	Shaft "M"	1
27558	03	Piston Sleeve	1
27700	04	End Cap "E"	1
29836	04	End Cap "M"	
27073	05	Lock Ring	1
S27085		Hardware Kit without bleeders (includes items 105, 106, 113)	
	105	Set screw (Socket head; 5/16"-18 x .375")	4
	106	Screw (Socket hex flat head; 1/4"-20 x .375, Grade 8)	2
	113	Screw (Socket hex flat head; 1/4"-20 x .375, Grade 8)	4
27085-1		Hardware Kit with bleeders (includes items 105, 113, 412)	
	105	Set screw (Socket head; 5/16"-18 x .375")	4
	113	Screw (Socket hex flat head; 1/4"-20 x .375, Grade 8)	4
	412	Bleeder plug (1/8"-27 NPT)	2
OEM	400	Stop tube (contact OEM of the equipment installed on)	1
OEM	420 & 422	Pin Bushings (contact OEM of equipment installed on)	
OEM	401	Counterbalance Valve or Motion Control Valve Kit (includes valve, mounting screws and o-rings) Contact OEM of equipment install on for correct valve kit	1

Note: Parker-Helac supplies many different counterbalance and motion control valves specific to an OEM application. Contact the OEM of the equipment installed on to purchase the correct valve.

Part Number	Item #	Description	Qty
S27083		Seal Kit Standard (Includes items below)	
	200	T-Seal	1
	202	T-Seal	1
	204	O-ring	1
	205	Cup Seal	2
	206	O-ring	2
	207	Back-up ring	1
S27084		Bearing Kit (Includes item below)	
	302	Bearing	2
	304	Thrust Washer	2

Parts in kits not sold individually

Seal kits can be ordered online at

<http://www.parker.com/helac>

Parts List - L20-39

Parts listed are standard components per the catalog. Parker-Helac has and does make special designs for OEM's that may differ. Model codes beginning with L20-39-S, L20-39-ES or L20-39-MS could use different parts.

"E" Shaft and end cap tapped for SAE bolts. SAE oil ports in housing.

"M" Shaft and end cap tapped for metric bolts. SAE oil ports in housing.

Parts

Part Number	Item #	Description	Qty
OEM	01	Housing - Clevis Mount (contact OEM of equipment installed on)	1
27355-2	01	Housing - Foot Mount (no valve flat) SAE-4 ports	1
27355-1	01	Housing - Foot Mount (with valve flat) SAE-4 ports	1
27898	02	Shaft "E"	1
33572	02	Shaft "M"	1
27116	03	Piston Sleeve	1
27117	04	End Cap "E"	1
33574	04	End Cap "M"	1
27118	05	Lock Ring	1
941009	103	Sealing screw (SeelSkrew R10-24X1/4-4601) pan head (if used)	2
		Hardware Kit (Includes item 105, 106, 113)	
27128-3	105	Set screw (Socket head; 5/16"-18 x .375")	4
	106	Port Plug (SAE-4)	4
	113	Screw (Socket hex flat head; 1/4"-20 x .375, Grade 8)	4
OEM	420 & 422	Pin Bushings (contact OEM of equipment installed on)	
OEM	401	Counterbalance Valve or Motion Control Valve Kit (includes valve, mounting screws and o-rings) Contact OEM of equipment install on for correct valve kit	
		CB Valve	1
		Socket head cap screw; 1/4"-20 x 1.50" ASTM A574	3
		Port plug: SAE-4 Hollow hex, o-ring	2

Note: Parker-Helac supplies many different counterbalance and motion control valves specific to an OEM application. If the valve you have is not one of the part numbers listed, contact the OEM of the equipment installed on to purchase the correct valve.

Part Number	Item #	Description	Qty
S27126		Seal Kit Standard (Includes items below)	
	200	T-Seal	1
	202	T-Seal	1
	204	O-ring	1
	205	Cup Seal	2
	206	O-ring	2
	207	Back-up ring	1
S27127		Bearing Kit (Includes item below)	
	302	Bearing	2
	304	Thrust Washer	2

Parts in kits not sold individually

Seal kits can be ordered online at

<http://www.parker.com/helac>

Before Disassembly

Before Disassembly

NOTICE

All numbers that appear in parenthesis () refer to items in parts list on page 14-19.

Inspect the actuator for corrosion prior to disassembly. Severe corrosion can make it difficult to remove the lock pins (109) and unthread the end cap (04). If corrosion is evident, soak the lock pins and end cap with penetrating oil for several hours before disassembling.

Disassembly is considerably easier if the actuator is firmly secured to the work bench. A pipe vise or mounting fixture work well.

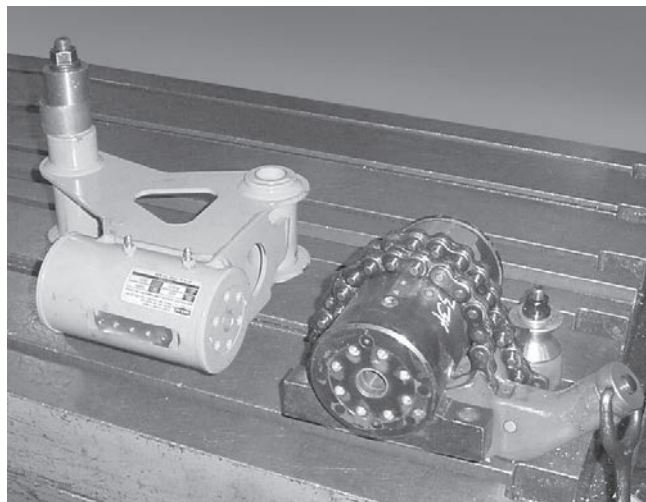

End Cap Removal

NOTICE

Units are being shipped without timing marks. Please note instructions related to indicating timing.

	WARNING
	Avoid personal injury and machinery damage: Read the Service and Repair Manual for proper installation, maintenance and repair procedures.

	CAUTION
	Spraying fluids. Contents under pressure. Wear approved eye protection. Use caution when removing port plugs and fittings.

CAUTION
To avoid injury or damage to product: Secure product to slotted table or vise.

NOTICE
To avoid contamination to machined parts: Make sure work area is clean.

L20-4.5, 8.2, 15

Pin Lock End Cap

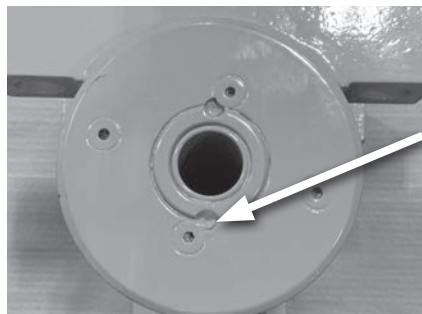

Lock pins inserted into holes, drilled post-assembly

Go to Pin Lock End Cap Removal - Page 21

Lock Ring End Cap

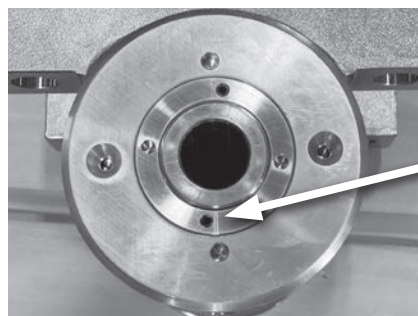

Left-Hand Thread Lock Ring

Go to Lock Ring End Cap Removal - Page 23

Pin Lock End Cap Removal

1. Remove port plugs (106) and drain oil. Inspect oil for signs of contamination, i.e. water, metal shavings.
2. Remove the cap screws (113) that cover the end cap lock pins (109).
3. Using a 1/8" (3 mm) drill bit, drill a hole in the center of each lock pin to a depth of approximately 3/16" (5 mm).



4. Remove the lock pins using a screw extracting tool such as an Easy Out™ (a size #2 is shown).

If the pin cannot be removed with the screw extractor, use a 5/16" bit to drill out the entire pin. Do not drill deeper than 1/2" (12.7 mm).



5. Install the end cap removal tools provided with the Helac seal kit. (1/4-20)



Using a metal bar or similar tool, unthread the end cap (04) by turning it counterclockwise.



Pin Lock End Cap Removal

6. Remove the end cap (04) and carefully set aside for later inspection.



Remove the stop tube (400) if the actuator is equipped with one. The stop tube is an available option that limits the rotation of the actuator.



Lock Ring End Cap Removal

1. Remove port plugs (106) and drain oil. Inspect oil for signs of contamination, i.e. water, metal shavings.
2. Remove two set screws (113) holding the lock ring using a 3/32 hex key.

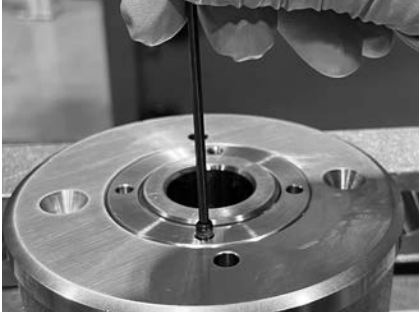

3. Remove the left hand threaded lock ring by rotating it clockwise, using 3/16" x 1 1/2" dowel pins in the correct spanner holes in the lock ring and corresponding holes.

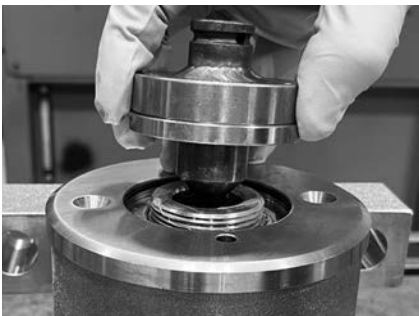

4. Remove the end cap seal (208)

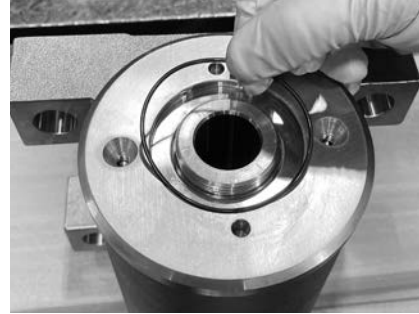

5. Using a metal bar or similar tool, unthread the end cap (04) by turning it counterclockwise.

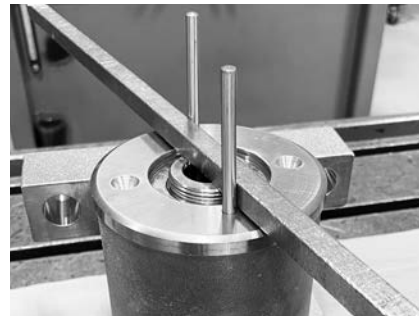

End Cap Removal

L20-25 and 39

1. Remove locking set screws using a screw driver.

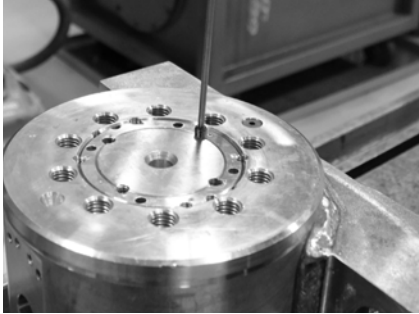

2. Screw in bolts. Then using a metal bar or similar tool, unthread the lock ring

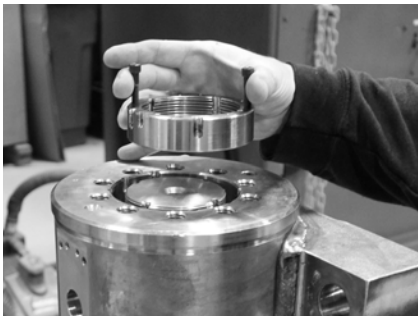

3. Use lifting eye bolts to remove end cap

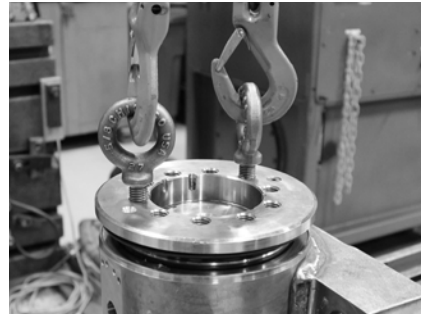

Disassembly

1. Some actuators have two sets of small punched timing marks that indicate timing between the gear sets. The location and appearance of the marks can vary slightly between models. One set indicates the timing between the piston sleeve (03) and the housing (01), the second set between the piston and the shaft (lower photo). To ensure correct rotation and accurate end positions, it is essential that the actuator be correctly timed when it is reassembled. If present, the punched timing marks can be used, but it is recommended to make timing marks with a marker before disassembly as outlined in steps 10 and 11 below.



2. Prior to removing the shaft (02), use a felt marker to clearly indicate the timing between shaft and piston sleeve (03). This will greatly simplify timing when the actuator is reassembled.



3. Remove the shaft (02) by rotating counterclockwise. As the shaft is rotated, it will disengage from the piston sleeve (03) and can be removed. It may be necessary to strike the threaded end of the shaft with a rubber mallet.

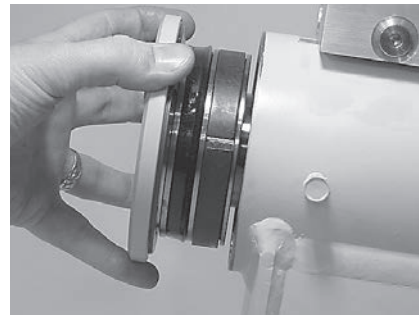

4. As in step 9 above, before removing the piston (03), mark the housing (01) ring gear in relation to the piston outside diameter gear. There should now be timing marks on the housing (01) ring gear, the piston (03) and the shaft (02).



Disassembly

- 5. To remove the piston (03) use a rubber mallet and a plastic mandrel so the piston and housing bore are not damaged.



- 6. At the point when the piston gear teeth come out of engagement with the housing gear teeth, mark the piston and housing with a marker as shown.

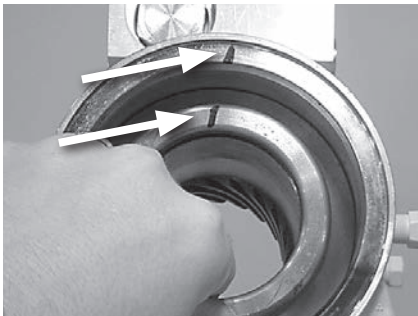

- 7. Remove the O-ring (204) and backup ring (207) from end cap (04).

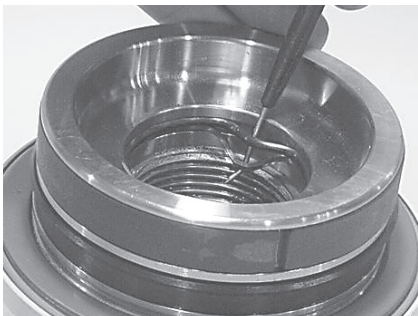

- 8. Remove the wear guide (302) from the end cap (04) and shaft (02).



- 9. Remove the main pressure seal (205).



- 10. Remove the thrust washer (304) from the end cap (04) and shaft (02).

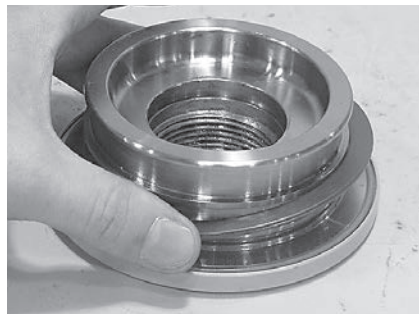

NOTICE
To avoid damage to machined parts:
Carefully remove seals using removal tools with rounded edges.

Disassembly

11. Remove the O-ring (206) from its groove in the end cap (04) and shaft (02).



12. Remove the outside diameter piston seal (202) from the piston.



13. Remove the inside diameter piston seal (200).



Inspection

**NOTICE**

Prior to assembly of actuator, these steps must be closely followed to insure proper operation of the actuator.

1. Clean all parts in a solvent tank and dry with compressed air prior to inspecting.
2. Carefully inspect all critical areas for any surface finish abnormalities: Seal grooves, bearing grooves, thrust surfaces, shaft surface, housing bore and gear teeth.

NOTICE

Small or minor surface scratches can be carefully polished.

Assembly



1. Gather all the components and tools into one location prior to re-assembly. Use the cut away drawing to reference the seal orientations.



2. Coat the thrust washers (304) with a generous amount of Lithium grease. Install the thrust washer (304) onto shaft (02) and end cap (04).

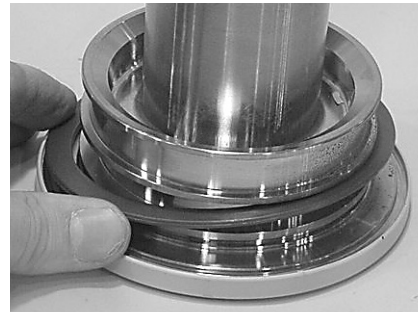

3. Install the exclusion seal (206) into the appropriate grooves on the shaft (02) and end cap (04) around the outside edge of the thrust washer (304).



Assembly

4. Using a seal tool (see Tools Required on page 6) install the main pressure seal (205) onto shaft (02) and end cap (04). Use the seal tool in a circular motion.

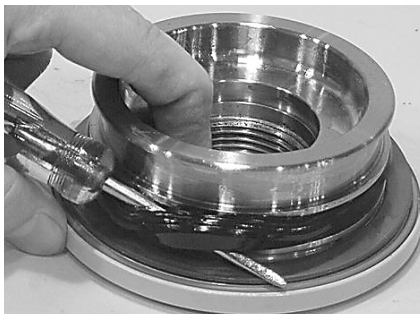

5. Install the wear guide (302) on the end cap (04) and shaft (02).



6. Install the O-ring (204) and back-up ring (207) into the inner seal groove on the end cap (04).



7. Install the inner T-seal (200) into the appropriate groove in the piston (03). Use a circular motion to insure the seal is correctly seated in the groove.

Install the outer T-seal (202) by stretching it around the groove in a circular motion.

Each T-seal has 2 back-up rings (see Assembly Drawing on page 8 for orientation).

Beginning with the inner seal (200) insert one end of backup ring in the lower groove and feed the rest in using a circular motion. Make sure the wedged ends overlap correctly.

Insert the other back up ring in upper groove.

Repeat both of these steps for the outer seal (202).



Assembly

- 8.** Insert the piston (03) into the housing (01) as shown, until the outer piston seal (202) contacts the inside housing bore.

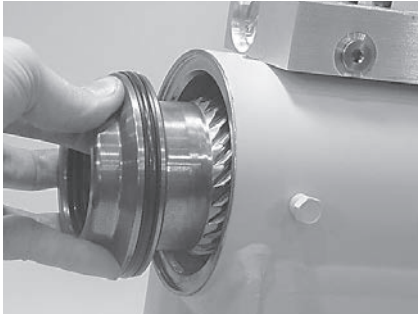

- 9.** Looking into the housing bore from the shaft flange end, rotate the piston (03) until the marks you put on the piston and the housing (01) during disassembly align as shown. Using a rubber mallet, tap the piston into the housing until the gear teeth contact.



- 10.** Looking into the bore from the opposite end of the housing (01) be sure the timing marks align correctly. Rotate the piston as necessary until aligned, then gently tap the piston (03) into the housing until the gear teeth mesh together. Tap the piston into the housing until it completely bottoms out against the ring gear.

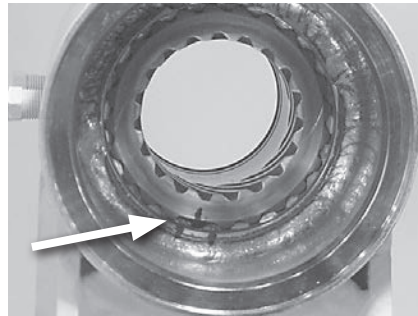

- 11.** Insert the shaft (02) into the piston (03). Be careful not to damage the piston seals. Do not engage the piston gear teeth yet.

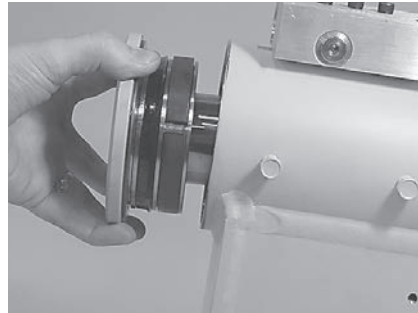

Assembly

- 12.** Looking at the actuator from the end opposite the shaft flange, use the existing timing marks to align the gear teeth on the shaft (02) with the gear teeth on the inside of the piston (03). When the marks align, gently tap the flange end of the shaft with a rubber mallet until the gear teeth engage.

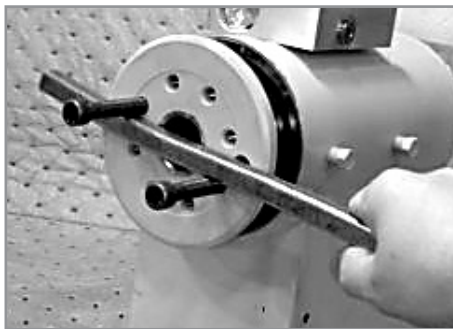

- 13.** Install two bolts in the threaded holes in the flange. Using a metal bar, rotate the shaft in a clockwise direction until the wear guides are seated inside the housing bore.

**NOTICE**

As the shaft is rotated, be careful not to disengage the piston and housing gearing.

- 14.** Install the stop tube (400) onto the shaft end if necessary. Stop tubes are an available option to limit the rotation of an actuator.

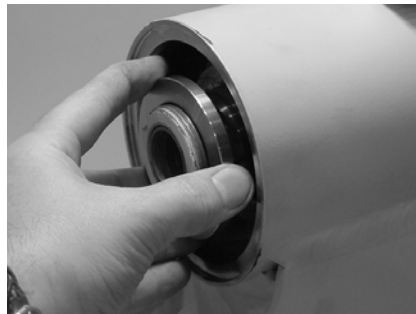

- 15.** Coat the threads on the end of the shaft with anti-seize grease to prevent galling.



End cap Installation

L20-4.5, 8.2 and 15

Pin Lock End Cap Installation

1. Thread the end cap (04) onto the shaft (02). Make sure the wear guide remains in place on the end cap as it is threaded into the housing (01).



2. Tighten the end cap (04) using a metal bar. In most cases the original holes for the lock pins will align.



3. Insert the lock pins (109) provided with the Helac seal kit into the holes with the dimple side up. Then, using a punch, tap the lock pins to the bottom of the hole.



4. Insert the cap screws (113) over the lock pins. Tighten to 25 in-lbs. (2.8 Nm).

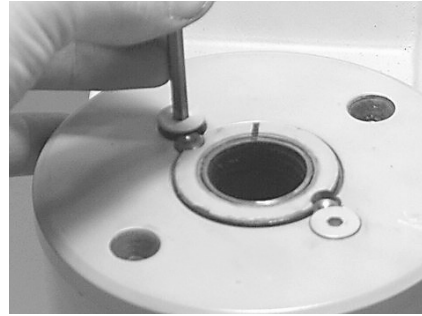

Rod Lock End Cap Installation

1. Using a metal bar or similar tool, unthread the end cap (04) by turning it counterclockwise.

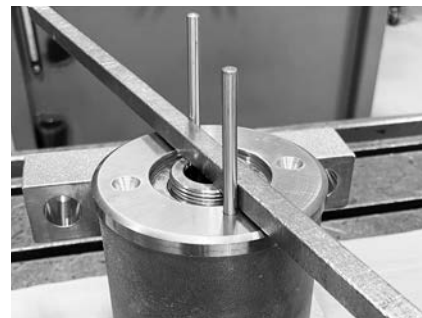

2. Torque end cap (04) to 105 ft-lbs (143 Nm)



End cap Installation

3. Install the end cap seal (208)

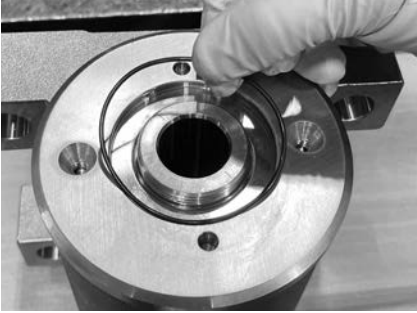

4. Grease thread hole

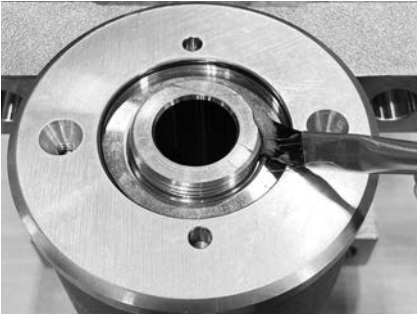

5. Install and tighten left hand lock ring by turning counterclockwise. Torque lock ring to approximately 33 ft-lb (45 Nm) using 3/16" dowel pins in the correct spanner holes.



End cap Installation

7. Install two set screws (113) using a 3/32" hex key

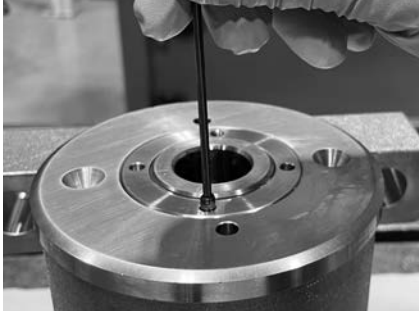

8. Torque set screws to approximately 72 in-lbs (8 Nm).



L20-25 and 39

1. Use lifting eye bolts to install end cap



2. Ensure end cap bolt pattern is aligned with shaft bolt pattern

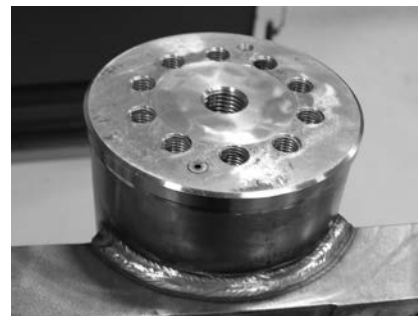
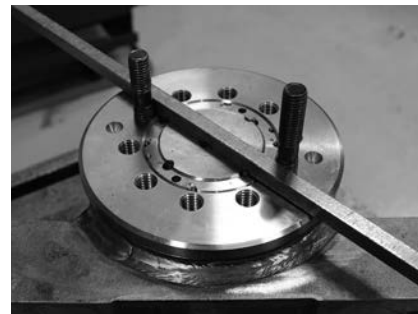

End Cap Installation

3. ScREW in bolts. Then using a metal bar or similar tool to tighten the lock ring
4. Insert locking set screws and tighten with a screw driver.

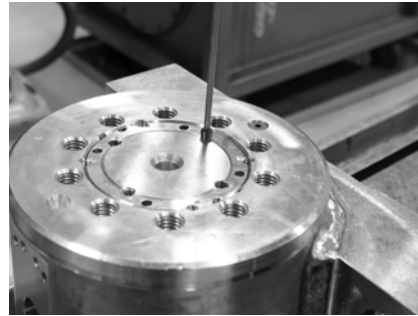

Greasing Thrust Washers

1. After the actuator is assembled but before it is put into service, the thrust washer area must be packed with Lithium grease.

There are two grease ports located on both the shaft flange and the end cap. They are plugged with cap screws (113) or set screws. Remove the grease port screws from the shaft flange and end cap. (See exploded view on page 9 and 11)

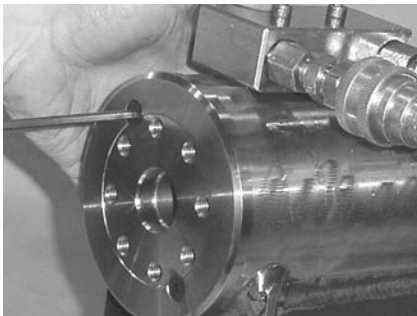

NOTICE

If a hydraulic test bench is not available, the actuator can be rotated by hand, open the pressure ports and use a pry bar with cap screws inserted into the shaft flange to turn the shaft in the desired direction.

Insert the tip of a grease gun into one port and apply grease to the shaft flange. Continue applying until grease flows from the opposite port. Cycle the actuator five times and apply grease again. Repeat this process on the end cap. Insert the cap screws into the grease ports and tighten to 25 in-lbs. (2.8 Nm).

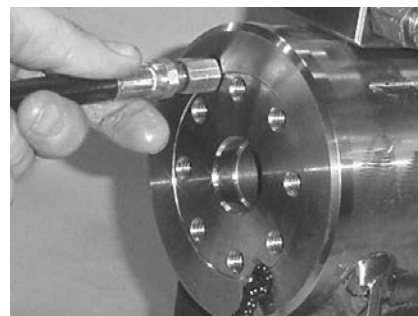

Testing the Actuator

Testing the Actuator



If the equipment is available, the actuator should be tested on a hydraulic test bench. The breakaway pressure — the pressure at which the shaft begins to rotate — should be approximately 500 psi (34 bar). Cycle the actuator at least 25 times at 3000 psi (207 bar) pressure. After the 25 rotations, increase the pressure to 4500 psi (315 bar) to check for leaks and cracks. Perform the test again at the end of the rotation in the opposite direction.

Testing the Actuator for Internal Leakage

If the actuator is equipped with a counterbalance valve, plug the valve ports. Connect the hydraulic lines to the housing ports. Bleed all air from the actuator (see *Installation and Bleeding* on page 38) Rotate the shaft to the end of rotation at 3000 psi (207 bar) and maintain pressure. Remove the hydraulic line from the non-pressurized side.

Continuous oil flow from the open housing port indicates internal leakage across the piston. Replace the line and rotate the shaft to the end of rotation in the opposite direction. Repeat the test procedure outlined above for the other port. If there is an internal leak, disassemble, inspect and repair.

Installation and Bleeding



After installation of the actuator on the equipment, it is important that all safety devices such as tie rods or safety cables are properly reattached.

To purge air from the hydraulic lines, connect them together to create a closed loop and pump hydraulic fluid through them. Review the OEM's operating manual and/or hydraulic schematic to determine which hydraulic lines to connect. The linear feet and inside diameter of the hydraulic supply lines together with pump capacity will determine the amount of pumping time required to fully purge the hydraulic system.

Bleeding may be necessary if excessive backlash is exhibited after the actuator is connected to the hydraulic system. The OEM does not specify all actuators with bleed nipples, see the drawing below for their location. The following steps are recommended when a minimum of two gallons (8 liters) is purged.

1. Connect a 3/16" inside diameter x 5/16" outside diameter x 5 foot clear, vinyl drain tube to each of the two bleed nipples. Secure them with hose clamps. Place the vinyl tubes in a clean 5-gallon container to collect the purged oil. The oil can be returned to the reservoir after this procedure is completed.
2. With an operator in the platform, open both bleed nipples a 1/4 turn. Hydraulically rotate the platform to the end of rotation (either clockwise or counterclockwise), and maintain hydraulic pressure. Oil with small air bubbles will be seen flowing through the tubes. Allow a 1/2 gallon of fluid to be purged from the actuator.
3. Keep the fittings open and rotate the platform in the opposite direction to the end position. Maintain hydraulic pressure until an additional 1/2 gallon of fluid is pumped into the container.
4. Repeat steps 2 & 3. After the last 1/2 gallon is purged, close both bleed nipples before rotating away from the end position.

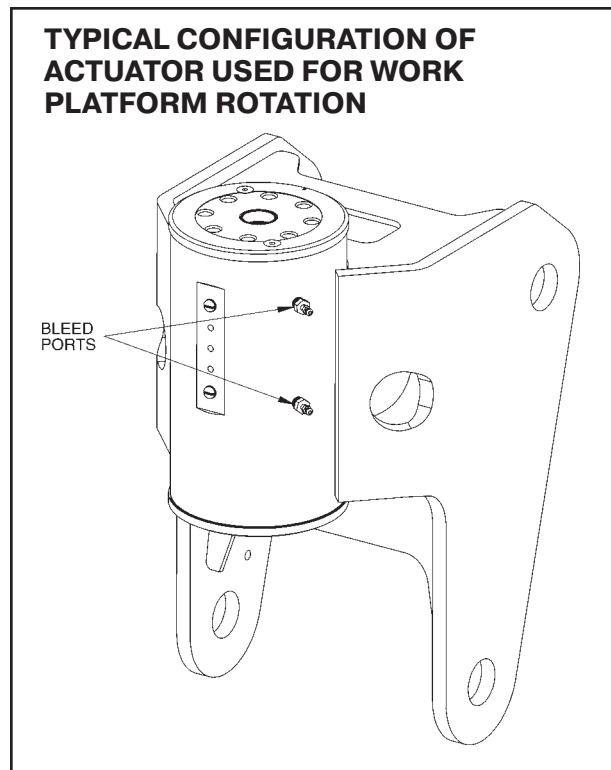

Troubleshooting Guide

PROBLEM	SEE CAUSES AND SOLUTIONS BELOW
Shaft rotates slowly or not at all	1-6
Operation is erratic or not responsive	7
Shaft will not fully rotate	8,9
Selected position cannot be maintained	3,4,7
CAUSE	SOLUTION
1. Insufficient torque output	Verify correct operating pressure. Do not exceed OEM's pressure specifications. Load may be above maximum capacity of the actuator.
2. Low rate of fluid flow	Inspect ports for obstructions and hydraulic lines for restrictions and leaks.
3. Control or Counterbalance valve has internal leak	Disconnect hydraulic lines and bypass valve. Leave valve ports open and operate the actuator through housing ports (do not exceed OEM's operating pressure). The valve must be replaced if a steady flow of fluid is seen coming from the valve ports.
4. Piston and/or shaft seal leak	Remove the plug and the housing's valve ports. Operate the actuator through the housing ports. Conduct the internal leakage test as described in the Testing Section on page 37 of this manual.
5. Corrosion build-up on the thrust surfaces	Re-build the actuator. Remove all rust and then polish.*
6. Swollen seals and composite bearings caused by incompatible hydraulic fluid (Standard actuators only)	Re-build the actuator. Use fluid that is compatible with seals and bearings. Contact Parker Hannifin for more information
7. Air in actuator	Purge air from actuator. See bleeding procedure starting on page 38.
8. Twisted or chipped gear teeth from overload conditions.	Check for binding. Actuator may or may not be able to be rebuilt and may need to be replaced.
9. Port fittings are obstructing the piston during stroke	Check thread length of port fittings. Fittings should not reach inside the housing bore.

* Replacement parts may be needed.

The items described in this document and other documents and descriptions provided by Parker Hannifin Corporation, its subsidiaries and its authorized distributors ("Seller") are hereby offered for sale at prices to be established by Seller. This offer and its acceptance by any customer ("Buyer") shall be governed by all of the following Terms and Conditions. Buyer's order for any item described in its document, when communicated to Seller verbally, or in writing, shall constitute acceptance of this offer. All goods, services or work described will be referred to as "Products".

1. Terms. All sales of Products by Seller will be governed by, and are expressly conditioned upon Buyer's assent to, these Terms. These Terms are incorporated into any Quote provided by Seller to Buyer. Buyer's order for any Products whether communicated to Seller verbally, by electronic data interface or other electronic commerce, shall constitute acceptance of these Terms. Seller objects to any writing or additional terms or conditions of Buyer. Reference in Seller's order acknowledgement to Buyer's purchase order or purchase order number shall in no way constitute an acceptance of any of Buyer's terms or conditions of purchase. Any Quote made by Seller to Buyer shall be considered a firm and definite offer and shall not be deemed to be otherwise despite any language on the face of the Quote. Seller reserves all rights to accept or reject any purported acceptance by Buyer to Seller's Quote if such purported acceptance attempts to vary the terms of the Quote. If Seller ships Products after Buyer issues an acceptance to the Quote, any additional or different terms proposed by Buyer will not become part of the parties' business relationship unless agreed to in a writing that is signed by an authorized representative of Seller, excluding email correspondence. If the transaction proceeds without such agreement on the part of Seller, the business relationship will be governed solely by these Terms and the specific terms in Seller's Quote.

2. Price; Payment. The Products set forth in the Quote are offered for sale at the prices indicated in the Quote. Unless otherwise specifically stated in the Quote, prices are valid for thirty (30) days and do not include any sales, use, or other taxes or duties. Seller reserves the right to modify prices for any reason and at any time by giving ten (10) days prior written notice. Unless otherwise specified by Seller, all prices are F.C.A. Seller's facility (INCOTERMS 2020). All sales are contingent upon credit approval and full payment for all purchases is due thirty (30) days from the date of invoice (or such date as may be specified in the Quote). Under any circumstances, Buyer may not withhold or suspend payment of any amounts due and payable as a deduction, set-off or recoupment of any amount, claim or dispute with Seller. Unpaid invoices beyond the specified payment date incur interest at the rate of 1.5% per month or the maximum allowable rate under applicable law. Seller reserves the right to require advance payment or provision of securities for first and subsequent deliveries if there is any doubt, in Seller's sole determination, regarding the Buyer's creditworthiness or for other business reasons. If the requested advance payment or securities are not provided to Seller's satisfaction, Seller reserves the right to suspend performance or reject the purchase order, in whole or in part, without prejudice to Seller's other rights or remedies, including the right to full compensation. Seller may revoke or shorten any payment periods previously granted in Seller's sole determination. The rights and remedies herein reserved to Seller are cumulative and in addition to any other or further rights and remedies available at law or in equity. No waiver by Seller of any breach by Buyer of any provision of these terms will constitute a waiver by Seller of any other breach of such provision.

3. Shipment; Delivery; Title and Risk of Loss. All delivery dates are approximate, and Seller is not responsible for damages or additional costs resulting from any delay. All deliveries are subject to our ability to procure materials from our suppliers. Regardless of the manner of shipment, delivery occurs and title and risk of loss or damage pass to Buyer, upon placement of the Products with the carrier at Seller's facility. Unless otherwise agreed prior to shipment and for domestic delivery locations only, Seller will select and arrange, at Buyer's sole expense, the carrier and means of delivery. When Seller selects and arranges the carrier and means of delivery, freight and insurance costs for shipment to the designated delivery location will be prepaid by Seller and added as a separate line item to the invoice. Buyer shall be responsible for any additional shipping charges incurred by Seller due to Buyer's acts or omissions. Buyer shall not return or repackage any Products without the prior written authorization from Seller, and any return shall be at the sole cost and expense of Buyer.

4. Warranty. The warranty for the Products is as follows: (i) Goods are warranted against defects in material or workmanship for a period of eighteen (18) months from the date of delivery or 2,000 hours of use, whichever occurs first; (ii) Services shall be performed in accordance with generally accepted practices and using the degree of care and skill that is ordinarily exercised and customary in the field to which the Services pertain and are warranted for a period of six (6) months from the date of completion of the Services; and (iii) Software is only warranted to perform in accordance with applicable specifications provided by Seller to Buyer for ninety (90) days from the date of delivery or, when downloaded by a Buyer or end-user, from the date of the initial download. All prices are based upon the exclusive limited warranty stated above, and upon the following disclaimer: **EXEMPTION CLAUSE; DISCLAIMER OF WARRANTY, CONDITIONS, REPRESENTATIONS, THIS WARRANTY IS THE SOLE AND ENTIRE WARRANTY, CONDITION, AND REPRESENTATION, PERTAINING TO PRODUCTS. SELLER DISCLAIMS ALL OTHER WARRANTIES, CONDITIONS, AND REPRESENTATIONS, WHETHER STATUTORY, EXPRESS OR IMPLIED, INCLUDING BUT NOT LIMITED TO THOSE RELATING TO DESIGN, NON-INFRINGEMENT, MERCHANTABILITY, AND FITNESS FOR A PARTICULAR PURPOSE. SELLER DOES NOT WARRANT THAT THE SOFTWARE IS ERROR-FREE OR FAULT-TOLERANT, OR THAT BUYER'S USE THEREOF WILL BE SECURE OR UNINTERRUPTED, UNLESS OTHERWISE AUTHORIZED IN WRITING BY SELLER. THE SOFTWARE SHALL NOT BE USED IN CONNECTION WITH HAZARDOUS OR HIGH-RISK ACTIVITIES OR ENVIRONMENTS. EXCEPT AS EXPRESSLY STATED HEREIN, ALL PRODUCTS ARE PROVIDED "AS IS".**

5. Claims; Commencement of Actions. Buyer shall promptly inspect all Products upon receipt. No claims for shortages will be allowed unless reported to Seller within ten (10) days of delivery. Buyer shall notify Seller of any alleged breach of warranty within thirty (30) days after the date the non-conformance is or should have been discovered by Buyer. Any claim or action against Seller based upon breach of contract or any other theory, including tort, negligence, or otherwise must be commenced within twelve (12) months from the date of the alleged breach or other alleged event, without regard to the date of discovery.

6. LIMITATION OF LIABILITY. IN THE EVENT OF A BREACH OF WARRANTY, SELLER WILL, AT ITS OPTION, REPAIR OR REPLACE THE NON-CONFORMING PRODUCTS, RE-PERFORM THE SERVICES, OR REFUND THE PURCHASE PRICE PAID WITHIN A REASONABLE PERIOD OF TIME. IN NO EVENT IS SELLER LIABLE FOR ANY SPECIAL, INDIRECT, INCIDENTAL OR CONSEQUENTIAL DAMAGES INCLUDING ANY LOSS OF REVENUE OR PROFITS, WHETHER BASED IN CONTRACT, TORT OR OTHER LEGAL THEORY. IN NO EVENT SHALL SELLER'S LIABILITY UNDER ANY CLAIM MADE BY BUYER EXCEED THE PURCHASE PRICE PAID FOR THE PRODUCTS.

7. Confidential Information. Buyer acknowledges and agrees that Confidential Information has been and will be received in confidence and will remain the property of Seller. Buyer further agrees that it will not use Seller's Confidential Information for any purpose other than for the benefit of Seller and shall return all such Confidential Information to Seller within thirty (30) days upon request.

8. Loss to Buyer's Property. Buyer's Property will be considered obsolete and may be destroyed by Seller after two (2) consecutive years have elapsed without Buyer ordering the Products manufactured using Buyer's Property. Also, Seller shall not be responsible for any loss or damage to Buyer's Property while it is in Seller's possession or control.

9. Special Tooling. Seller may impose a tooling charge for any Special Tooling. Special Tooling shall be and remain Seller's property. In no event will Buyer acquire any interest in the Special Tooling, even if such Special Tooling has been specially converted or adapted for manufacture of Goods for Buyer and notwithstanding any charges paid by Buyer. Unless otherwise agreed, Seller has the right to alter, discard or otherwise dispose of any Special Tooling or other property owned by Seller in its sole determination at any time.

10. Security Interest. To secure payment of all sums due from Buyer, Seller retains a security interest in all Products delivered to Buyer, and Buyer's acceptance of these Terms is deemed to be a Security Agreement under the Uniform Commercial Code. Buyer authorizes Seller as its attorney to execute and file on Buyer's behalf all documents Seller deems necessary to perfect Seller's security interest.

11. User Responsibility. Buyer, through its own analysis and testing, is solely responsible for making the final selection of the Products and assuring that all performance, endurance, maintenance, safety and warning requirements of the application of the Products are met. Buyer must analyze all aspects of the application and follow applicable industry standards, specifications, and any technical information provided with the Quote or the Products, such as Seller's instructions, guides and specifications. If Seller provides options of or for Products based upon data or specifications provided by Buyer, Buyer is responsible for determining that such data and specifications are suitable and sufficient for all applications and reasonably foreseeable uses of the Products. In the event Buyer is not the end-user of the Products, Buyer will ensure such end-user complies with this paragraph.

12. Use of Products. Indemnity by Buyer. Buyer shall comply with all instructions, guides and specifications provided by Seller with the Quote or the Products. If Buyer uses or resells the Products in any way prohibited by Seller's instructions, guides or specifications, or Buyer otherwise fails to comply with Seller's instructions, guides and specifications, Buyer acknowledges that any such use, resale, or non-compliance is at Buyer's sole risk. Further, Buyer shall indemnify, defend, and hold Seller harmless from any losses, claims, liabilities, damages, lawsuits, judgments and costs (including attorney fees and defense costs), whether for personal injury, property damage, intellectual property infringement or any other claim, arising out of or in connection with: (a) improper selection, design, specification, application, or any misuse of Products; (b) any act or omission, negligent or otherwise, of Buyer; (c) Seller's use of Buyer's Property; (d)

damage to the Products from an external cause, repair or attempted repair by anyone other than Seller, failure to follow instructions, guides and specifications provided by Seller, use with goods not provided by Seller, or opening, modifying, deconstructing, tampering with or repackaging the Products; or (e) Buyer's failure to comply with these Terms, including any legal or administrative proceedings, collection efforts, or other actions arising from or relating to such failure to comply. Seller shall not indemnify Buyer under any circumstance except as otherwise provided in these Terms.

13. Cancellations and Changes. Buyer may not cancel or modify, including but not limited to movement of delivery dates for the Products, any order for any reason except with Seller's written consent and upon terms that will indemnify, defend and hold Seller harmless against all direct, incidental and consequential loss or damage and any additional expense. Seller, at any time, may change features, specifications, designs and availability of Products.

14. Assignment. Buyer may not assign its rights or obligations without the prior written consent of Seller.

15. Force Majeure. Seller is not liable for delay or failure to perform any of its obligations by reason of any events or circumstances beyond its reasonable control. Such circumstances include without limitation: accidents, labor disputes or stoppages, government acts or orders, acts of nature, pandemics, epidemics, other widespread illness, or public health emergency, cyber related disruptions, cyber-attacks, ransomware sabotage, delays or failures in delivery from carriers or suppliers, shortages of materials, sudden increases in the price of raw material or components, shutdowns or slowdowns affecting the supply of raw materials or components, or the transportation thereof, oil shortages or oil price increases, energy crisis, energy or fuel interruption, war (whether declared or not) or the serious threat of same, riots, rebellions, acts of terrorism, embargoes, fire or any reason whether similar to the foregoing or otherwise. Seller will resume performance as soon as practicable after the event of force majeure has been removed. All delivery dates affected by an event of force majeure shall be tolled for the duration of such event of force majeure and rescheduled for mutually agreed dates as soon as practicable after the event of force majeure ceases to exist. The right to allocate capacity is in the Seller's sole discretion. An event of force majeure shall not include financial distress, insolvency, bankruptcy, or other similar conditions affecting one of the parties, affiliates and/or sub-contractors. An event of force majeure in the meaning of these Terms means any circumstances beyond Seller's control that permanently or temporarily hinders performance, even where that circumstance was already foreseen. Buyer shall not be entitled to cancel any orders following its claim of an event of force majeure.

16. Waiver and Severability. Failure to enforce any provision of these Terms will not invalidate that provision; nor will any such failure prejudice either party's right to enforce that provision in the future. Invalidation of any provision of these Terms shall not invalidate any other provision herein and, the remaining provisions will remain in full force and effect.

17. Duration. Unless otherwise stated in the Quote, any agreement governed by or arising from these Terms shall: (a) be for an initial duration of one (1) year; and (b) shall automatically renew for successive one-year terms unless terminated by Buyer with at least 180-days written notice to Seller or if Seller terminates the agreement pursuant to Section 19 of these Terms.

18. Termination. Seller may, without liability to Buyer, terminate any agreement governed by or arising from these Terms for any reason and at any time by giving Buyer thirty (30) days prior written notice. Seller may immediately terminate, in writing, if Buyer: (a) breaches any provision of these Terms, (b) becomes or is deemed insolvent, (c) appoints or has appointed a trustee, receiver or custodian for all or any part of Buyer's property, (d) files a petition for relief in bankruptcy on its own behalf, or one is filed against Buyer by a third party, (e) makes an assignment for the benefit of creditors; or (f) dissolves its business or liquidates all or a majority of its assets.

19. Ownership of Rights. Buyer agrees that (a) Seller (and/or its affiliates) owns or is the valid licensee of Seller's IP and (b) the furnishing of information, related documents or other materials by Seller to Buyer does not grant or transfer any ownership interest or license in or to Seller's IP to Buyer, unless expressly agreed in writing. Without limiting the foregoing, Seller retains ownership of all Software supplied to Buyer. In no event shall Buyer obtain any greater right in and to the Software than a right in a license limited to the use thereof and subject to compliance with any other terms provided with the Software. Buyer further agrees that it will not, directly or through intermediaries, reverse engineer, decompile, or disassemble any Software (including firmware) comprising or contained within a Product, except and only to the extent that such activity may be expressly permitted, either by applicable law or, in the case of open source software, the applicable open source license.

20. Indemnity for Infringement of Intellectual Property Rights. Seller is not liable for infringement of any Intellectual Property Rights except as provided in this Section. Seller will defend at its expense and will pay the cost of any settlement or damages awarded in an action brought against Buyer based on a third-party claim that one or more of the Products infringes the Intellectual Property Rights of a third party in the country of delivery of the Products by Seller to Buyer. Seller's obligation to defend and indemnify Buyer is contingent on Buyer notifying Seller within ten (10) days after Buyer becomes aware of any such claim, and Seller having sole control over the defense of the claim including all negotiations for settlement or compromise. If one or more Products is subject to such claim, Seller may, at its sole expense and option, procure for Buyer the right to continue using the Products, replace or modify the Products to render them non-infringing, or offer to accept return of the Products and refund the purchase price less a reasonable allowance for depreciation. Seller has no obligation or liability for any claim of infringement: (i) arising from information provided by Buyer (including Seller's use of Buyer's Property); or (ii) directed to any Products for which the designs are specified in whole or part by Buyer; or (iii) resulting from the modification, combination or use in a system of any Products. The foregoing provisions of this Section constitute Seller's sole and exclusive liability and Buyer's sole and exclusive remedy for claims of infringement of Intellectual Property Rights.

21. Governing Law. These Terms, the terms of any Quote, and the sale and delivery of all Products are deemed to have taken place in, and shall be governed and construed in accordance with, the laws of the State of Ohio, as applicable to contracts executed and wholly performed therein and without regard to conflicts of laws principles. Buyer irrevocably agrees and consents to the exclusive jurisdiction and venue of the courts of Cuyahoga County, Ohio with respect to any dispute, controversy or claim arising out of or relating to the sale and delivery of the Products.

22. Entire Agreement. These Terms, along with the terms set forth in the Quote, forms the entire agreement between the Buyer and Seller and constitutes the final, complete and exclusive expression of the terms of sale and purchase. In the event of a conflict between any term set forth in the Quote and these Terms, the terms set forth in the Quote shall prevail. All prior or contemporaneous written or oral agreements or negotiations with respect to the subject matter shall have no effect. No modification to these Terms will be binding on Seller unless agreed to in a writing that is signed by an authorized representative of Seller, excluding email correspondence, "clickwrap" or other purported electronic assent to different or additional terms. Sections 2-25 of these Terms shall survive termination or cancellation of any agreement governed by or arising from these Terms.

23. No 'Wrap' Agreements/No Authority to Bind. Seller's clicking any buttons or any similar action, such as clicking "I Agree" or "Confirm", to utilize Buyer's software or webpage for the placement of orders, is NOT an agreement to Buyer's Terms and Conditions. NO EMPLOYEE, AGENT OR REPRESENTATIVE OF SELLER HAS THE AUTHORITY TO BIND SELLER BY THE ACT OF CLICKING ANY BUTTON OR SIMILAR ACTION ON BUYER'S WEBSITE OR PORTAL.

24. Compliance with Laws. Buyer agrees to comply with all applicable laws, regulations, and industry and professional standards, including those of the United States of America, and the country or countries in which Buyer may operate, including without limitation the U.S. Foreign Corrupt Practices Act ("FCPA"), the U.S. Anti-Kickback Act ("Anti-Kickback Act"), U.S. and E.U. export control and sanctions laws ("Export Laws"), the U.S. Food Drug and Cosmetic Act ("FDCA"), and the rules and regulations promulgated by the U.S. Food and Drug Administration ("FDA"), each as currently amended. Buyer agrees to indemnify, defend, and hold harmless Seller from the consequences of any violation of such laws, regulations and standards by Buyer, its employees or agents. Buyer represents that it is familiar with all applicable provisions of the FCPA, the Anti-Kickback Act, Export Laws, the FDCA, and the FDA and certifies that Buyer will adhere to the requirements thereof and not take any action that would make Seller violate such requirements. Buyer represents and agrees that Buyer will not make any payment or give anything of value, directly or indirectly, to any governmental official, foreign political party or official thereof, candidate for foreign political office, or commercial entity or person, for any improper purpose, including the purpose of influencing such person to purchase Products or otherwise benefit the business of Seller. Buyer further represents and agrees that it will not receive, use, service, transfer or ship any Products from Seller in a manner or for a purpose that violates Export Laws or would cause Seller to be in violation of Export Laws. Buyer agrees to promptly and reliably provide Seller all requested information or documents, including end-user statements and other written assurances, concerning Buyer's ongoing compliance with Export Law. 9/22

Notes

Notes

Notes

Parker Hannifin Corporation
Cylinder and Accumulator Division
225 Battersby Avenue
Enumclaw, WA 98022 USA
phone (360) 825-1601
fax (360) 825-1603
www.parker.com/helac

